

Grove RT540E

Product Guide



35 t



31 m



7,9 - 13,7 m



47 m

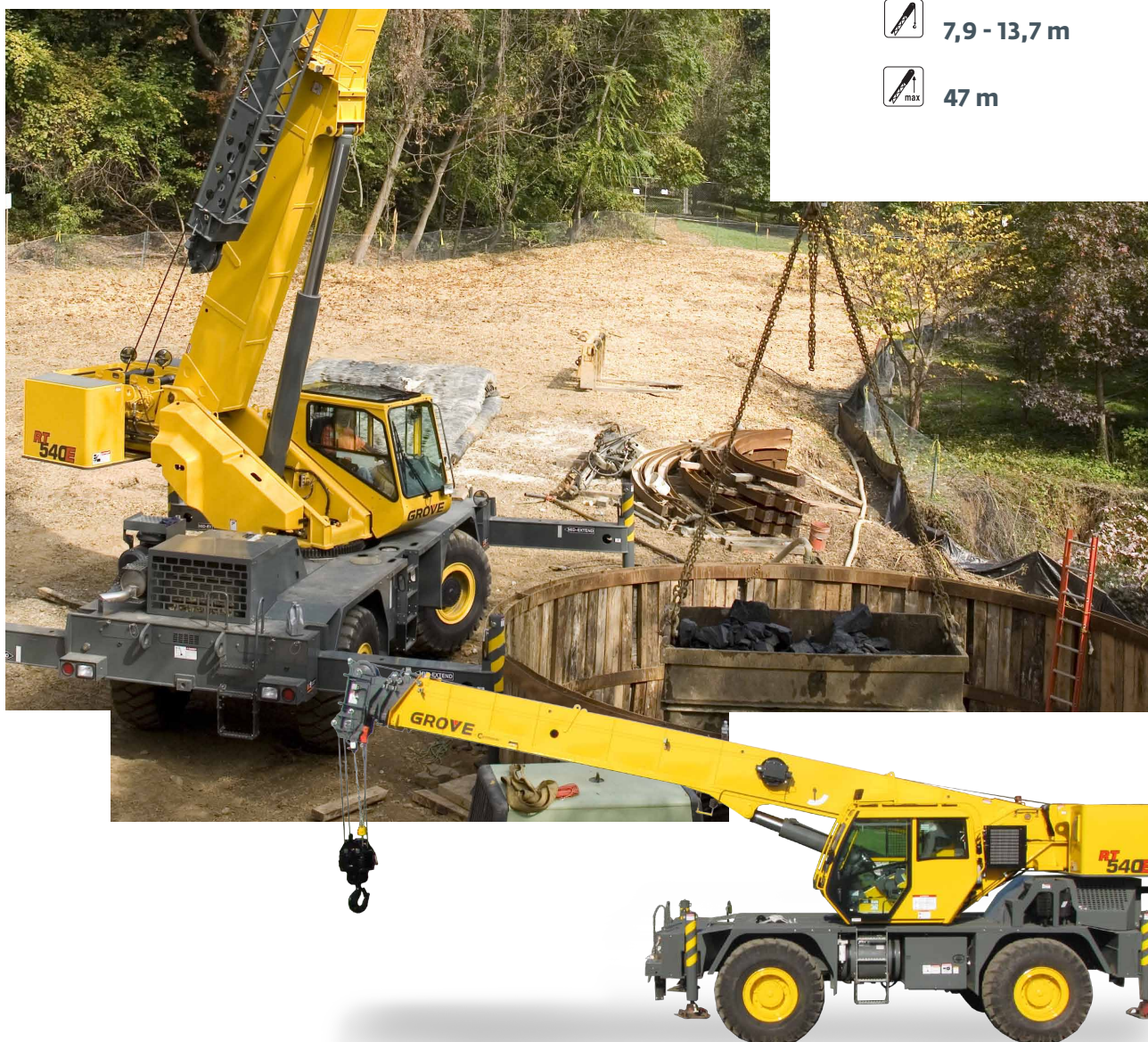

Rough Terrain Crane
Grúa para terrenos difíciles
Guindaste para terrenos acidentados

Features • Características • Características



- **Boom shape** - The RT540E is equipped with a 9,8 m - 31 m (32 ft - 102 ft) four-section full power boom. The boom incorporates a rectangular boom shape made from 100 k.s.i. steel which eliminates weight and maximizes structural capacities.
- **Forma de la pluma** - La RT540E está provista de una pluma de cuatro secciones completamente mecánica de 9,8 m - 31 m (32 pies - 102 pies). La pluma incorpora una forma rectangular fabricada en acero de 100 k.s.i. lo cual elimina peso e incrementa al máximo las capacidades estructurales.
- **Formato da lança** - O RT540E é equipado com uma lança de 9,8 m a 31 m (32 ft a 102 ft) totalmente motorizada, de quatro seções. A lança apresenta um formato retangular e é feita de aço 100 ksi, que reduz o peso e maximiza a capacidade estrutural.



• Cab

The Full Vision cab with tilt-telescoping steering wheel, dual-axis controllers, hot water heat and air conditioning provide all day comfort for the operator.

• Cabina

Cabina de vision completa con volante telescópico y abatible, controles duales de un solo eje, calefacción a base de agua caliente y aire acondicionado, proven comodidad al operador durante todo el día.

• Cabine

A cabine Visão completa com inclinação telescópica-volante, duplo eixo controladores, o calor da água quente e ar condicionado proporcionam todo o conforto para o operador ao longo dos dias.

CraneSTAR

- **CraneSTAR** is an exclusive and innovative crane asset management system that helps improve your profitability and reduce costs by remotely monitoring critical crane data. Visit www.cranestar.com for more information.
- **CraneSTAR** es un innovador sistema de gestión de flotas de grúas que ayuda a mejorar su rentabilidad y reducir los costos al permitir monitorear a distancia los datos críticos de las grúas. Visite el sitio Web www.cranestar.com para más información.
- **CraneSTAR** é um sistema de gerenciamento de recursos de guindastes exclusivo e inovador que ajuda a melhorar sua lucratividade e reduzir custos por meio do monitoramento remoto de dados críticos do guindaste. Acesse www.cranestar.com para obter mais informações.



- **Tip Height** – The RT540E offers a 7,9 m - 13,7 m (26 ft - 45 ft) offsettable telescopic swingaway providing a maximum tip height of 47 m (154 ft) with 13,7 m (45 ft).
- **Altura de punta** – La RT540E ofrece una articulación telescópica descentrable de 7,9 m - 13,7 m (26 pies - 45 pies) proporcionando una altura máxima de punta de 47 m (154 pies) con 13,7 m (45 pies).
- **Altura da ponta** – O RT540E oferece uma extensão articulada telescópica deslocável de 7,9 m a 13,7 m (26 ft a 45 ft) que fornece uma altura máxima da ponta de 47 m (154 ft) com 13,7 m (45 ft).

Specifications	4
Especificaciones	6
Especificações	8
Data • Datos • Dados	10
Dimensions • Dimensiones • Dimensões	11
Weight reductions • Reducciones de peso • Reduções de peso	12
Working range • Alcance de trabajo • Faixa de trabalho	13
Load charts • Tablas de carga • Tabelas de carga	14
Symbols glossary • Glosario de símbolos • Glossário de símbolos	21

Specifications

Superstructure

Boom

9,8m – 31,0m. Four-section, synchronized full power boom.
Maximum tip height: 33,6m.

*Telescopic swingaway extension

7,9m – 13,7m offsettable telescopic swingaway extension. Offsets 0°, 15° and 30°. Stows alongside base boom section.
Maximum tip height: 47 m.

Boom elevation

One double acting hydraulic cylinder with integral holding valve provides elevation from -3° to +78°.

Load moment and anti-two block system

Standard “Graphic Display” load moment and anti-two block system with audio-visual warning and control lever lockout. These systems provide electronic display of boom angle, length, radius, tip height, relative load moment, maximum permissible load, load indication and warning of impending two-block condition. The standard Work Area Definition System allows the operator to pre-select and define safe working areas. If the crane approaches the pre-set limits, audio-visual warnings aid the operator in avoiding job-site obstructions.

Cab

Full-vision, all-steel fabricated with acoustical lining and tinted safety glass throughout. Deluxe seat incorporates armrest-mounted hydraulic single-axis controllers. Tilt/telescoping steering wheel with various controls incorporated into the steering column. Other standard features include: hot water heater, cab circulating air fan, sliding side and rear windows, sliding skylight with electric wiper and sunscreen, electric windshield wash/wipe, fire extinguisher, seat belt, air conditioning, and dual cab mounted work light.

Slewing

Single speed, planetary swing drive with foot applied multi-disc wet brake. Spring applied, hydraulically released swing brake. Single position mechanical house lock, operated from cab.
Maximum speed: 2,0 RPM.

Counterweight

4,3 t. Pinned to superstructure.

Hydraulic system

Two main pumps ([1] piston and [1] gear) with a combined capacity of 316,5 LPM.

Maximum operating pressure: 275,7 bar.

Three section pressure compensated valve bank. Return line type filter with full flow by-pass protection and service indicator. Replaceable cartridge with micron filtration rating of 5/12/16. 396 L hyd. reservoir. System pressure test ports.

Hoist

Planetary reduction with automatic spring applied multi-disc wet brake. Electronic hoist drum rotation indicators, and hoist drum cable followers.

Maximum Single Line Pull:

- 1st layer: 5 280 kg.
- 3rd layer: 4 323 kg.
- 5th layer: 3 656 kg.

Maximum Permissible Line Pull:
5 280 kg. with 34x37 class rope.

Maximum Single Line Speed: 136 m/min.

Rope Construction: 34w x K7, rotation Resistant.

Rope Diameter: 16mm.

Rope Length: Main Hoist: 137 m - Auxiliary Hoist: 137 m.

Maximum Rope Stowage: 181 m.

Carrier



Carrier frame

Box section frame fabricated from high-strength, lowalloy steel. Combination lift/tie-down/towing lugs.



Outriggers

Four hydraulic telescoping single-stage double box beam outriggers with inverted jacks and integral holding valves.

Three position setting, 0%, 50% and fully extended.

All steel fabricated, quick release type outrigger floats, 362 mm diameter.

Maximum outrigger pad load: 26 300kg.

Controls and crane level indicator located in cab.



Engine

Cummins QSB 6.7 L diesel, six cylinders, 119 kW (160 bhp) (Gross) at 2500 rpm.

Maximum torque: 732 Nm (540 ft-lb) at 1500 rpm.



Transmission

Range-shift 6 speed (3 speeds x 2 range, both forward and reverse).

Front axle disconnect for 4 x 2 travel.



Drive/Steer

4 x 4.

Fully independent power steering:

Front: Full hydraulic steering wheel controlled.

Rear: Full hydraulic switch controlled.

Provides infinite variations of 4 main steering modes: front only, rear only, crab and coordinated. Rear steer indicator. Turning radius: 7,62 m.



Axles

Front: Drive/steer with differential and planetary reduction hubs rigid mounted to frame.

Rear: Drive/steer with differential and planetary reduction hubs pivot mounted to frame.



Tyres

Std. 20,5 x 25 - 24 bias ply.

Option: 16,0 x 25-28 bias ply.



Lights

Full lighting including turn indicators, head, tail, brake and hazard warning lights.



Maximum speed

40 kph at 2500 r.p.m.



Brakes

Full hydraulic split circuit operating on all wheels. Spring-applied, hydraulically released parking brake mounted on front axle.



Electrical system

Four (4) 12V maintenance free batteries. 24V starting and lighting. Battery disconnect. Full CanBus diagnostic system.

*Optional equipment

- Auxiliary Hoist Package: Includes model HP15C-17G auxiliary hoist with electronic hoist drum rotation indicator, hoist drum cable follower, 137 m of 16 mm 35 x 7 class wire rope and auxiliary sheave boom nose.
- Auxiliary Light and Convenience Package: Includes cab mounted amber flashing light, hoist mounted work lights, and dual base boom mounted floodlights, LMI light bar (in cab), rubber mat for stowage trough.
- 360° NYC style mechanical swing lock
- Rear Pintle hook
- Cab controlled cross axle differential locks, (front and rear)
- PAT event recorder down-load kit
- 4 sheaves hookblock

Especificaciones

Superestructura

Pluma

Pluma de cuatro secciones, sincronizada, completamente mecánica, 9,8 m a 31,0 m.

Altura máxima a la punta: 33,6 m.

*Extensión articulada telescópica

Extensión articulada telescópica y descentrable de 7,9 m a 13,7 m. Se descentra 0°, 15° y 30°. Se almacena al lado de la sección de base de la pluma.

Altura máxima de la punta: 47 m.

Elevación de pluma

Un cilindro hidráulico de doble acción con válvula de retención incorporada proporciona elevación de -3° a +78°.

Momento de carga y sistema de prevención del contacto entre bloques

Momento de carga con “pantalla gráfica” estándar y sistema de prevención del contacto entre bloques con advertencia sonora y visual y bloqueo de palancas de control. Estos sistemas proporcionan un desplegado electrónico del ángulo de la pluma, largo, radio, altura a la punta, momento de carga relativo, carga máxima admisible, indicación de carga y advertencia de la condición inminente del contacto entre bloques. El sistema de definición de la zona de trabajo estándar permite al operador preseleccionar y definir zonas de trabajo seguras. Si la grúa se aproxima a los límites preestablecidos, unas señales de advertencia sonoras y visuales ayudan al operador a evitar las obstrucciones en la obra.

Cabina

Visión completa, fabricada en acero con recubrimiento acústico y vidrios de seguridad entintados. Asiento de lujo el cual incorpora controladores hidráulicos montados en los descansabrazos.

Volante telescópico/abatible con varios controles incorporados en la columna del mismo. Otras características estándar incluyen: Calefacción a base de agua caliente, ventilador para circulación de aire en la cabina, ventanas deslizantes al costado y parte trasera, ventana superior deslizante con limpiaparabrisas eléctrico y malla de sombra, limpiaparabrisas eléctrico, extintor, cinturón de seguridad, aire acondicionado y luces de trabajo duales montadas en la cabina.

Inclinación

Mando de giro planetario de velocidad única con freno de discos múltiples en baño de aceite accionado por pedal. Freno de giro aplicado por resorte, liberado hidráulicamente. Bloqueo mecánico de caja de una sola posición, accionado desde la cabina. Velocidad máxima: 2,0 rpm.

Contrapeso

4,3 t, sujeto a la superestructura.

Sistema hidráulico

Dos bombas principales ([1] de émbolo y [1] de engranajes) con una capacidad combinada de 316,5 l/min.

Presión máxima de funcionamiento: 275,7 bar.

Banco de válvulas de presión compensada de tres secciones. Filtro en la línea de retorno con protección de derivación de caudal pleno e indicador de servicio. Cartucho reemplazable con clasificación de filtrado micrométrico de 5/12/16. Depósito hidráulico de 396 l. Lumbreras de prueba de presión del sistema.

Malacate

Reducción planetaria con freno automático de discos múltiples en baño de aceite aplicado por resorte. Indicadores electrónicos de rotación del tambor de malacate, y seguidores de cable del tambor de malacate.

Tracción máxima de cable sencillo:

- 1a capa: 5280 kg.
- 3a capa: 4323 kg.
- 5a capa: 3656 kg.

Tracción máxima admisible del cable:

5280 kg con cable de clase 34x37.

Velocidad máxima de cable sencillo: 136 m/min.

Construcción del cable: 34w x K7 resistente a la rotación.

Diámetro del cable: 16 mm.

Longitud del cable: Malacate principal: 137 m

Malacate auxiliar: 137 m.

Almacenamiento máximo de cable en tambor: 181 m.

Vehículo



Bastidor de vehículo

Bastidor en forma de cajón fabricado de acero de baja aleación y alta resistencia. Orejetas combinadas para elevación/amarre/remolcado.



Estabilizadores

Cuatro estabilizadores hidráulicos telescópicos con vigas de una etapa con gatos invertidos y válvulas de retención integradas. Tres ajustes de posición, 0%, 50% y completamente extendidos. Flotadores de estabilizadores de desconexión rápida fabricadas en acero, 362 mm de diámetro. Carga máxima de base de estabilizador: 26 300 kg. Controles e indicador de nivel de la grúa ubicados en la cabina.



Motor

Motor diesel Cummins QSB de 6,7 litros, seis cilindros, 119 kW (160 bhp) (bruto) a 2500 rpm. Par motor máximo: 732 Nm (540 lb-pie) a 1500 rpm.



Transmisión

Cambio de gama, 6 marchas (3 marchas x 2 gamas, avance y retroceso). Desconexión de eje delantero para tracción 4 x 2.



Tracción/dirección

4 x 4.

Dirección hidráulica completamente independiente:
Delantera: Completamente hidráulica controlada por volante de dirección.
Trasera: Completamente hidráulica controlada por interruptor. Ofrece variaciones infinitas de 4 modos de dirección principal: delantera solamente, trasera solamente, cangrejo y coordinada. Indicador de dirección trasera. Radio de giro: 7,62 m.



Ejes

Delantero: Tracción/dirección con diferencial y cubos de reducción planetaria rígidos montados en el bastidor.
Trasero: Tracción/dirección con diferencial y cubos de reducción planetaria pivotantes montados en el bastidor.



Neumáticos

Estándar 20.5 x 25 - 24 telas diagonales.
Opcionales: 16.0 x 25 - 28 telas diagonales.



Luces

Iluminación completa incluyendo señalizadores de viraje, faros, luces de cola, frenos y luces de advertencia.



Velocidad máxima

40 km/h a 2500 rpm.



Frenos

Circuito dividido completamente hidráulico funcionando en todas las ruedas. Freno de estacionamiento montado en el eje delantero, aplicado por resorte y liberado hidráulicamente.



Sistema eléctrico

Cuatro (4) baterías de 12 V exentas de mantenimiento. 24 V para arranque y alumbrado. Desconexión de baterías. Sistema de diagnóstico completo de bus CAN.

*Equipo opcional

- Paquete de malacate auxiliar: Incluye malacate auxiliar modelo HP15C-17G con indicador electrónico de rotación del tambor de malacate, seguidor de cable de tambor de malacate, 137 m de cable de 16 mm clase 35 x 7 y punta de pluma con polea auxiliar.
- Paquete de conveniencia y luces auxiliares: Incluye luz destellante ámbar instalada en la cabina, luces de trabajo instaladas en el malacate, y proyectores de base doble montados en la pluma, barra de luces LMI (en la cabina), cubierta de caucho para la cubeta de almacenamiento.
- Bloqueo de giro mecánico estilo NYC de 360°
- Gancho de clavija trasero
- Bloqueos de diferencial entre ruedas controlados desde la cabina (delantero y trasero)
- Juego de descarga de registro de eventos PAT
- Aparejo de gancho de 4 poleas

Especificações

Superestrutura

Lança

Lança totalmente motorizada de quatro seções e 9,8 m a 31,0 m.
Altura máxima da ponta: 33,6 m.

*Extensão articulada telescópica

Extensão articulada telescópica deslocável de 7,9 m a 13,7 m.
Desloca-se 0°, 15° e 30°. Retrai ao longo da seção da base da lança.
Altura máxima da ponta: 47 m.

Elevação da lança

Um cilindro hidráulico de dupla ação com válvula de retenção integral proporciona elevação de -3° a +78°.

Sistema de momento de carga e anticolisão do moitão

Sistema de momento de carga e anticolisão do moitão com "Mostrador gráfico" com advertência audiovisual e bloqueio da alavanca de controle. Esses sistemas oferecem exibição eletrônica do ângulo da lança, comprimento, raio, altura da ponta, momento de carga relativo, indicação de carga e advertência de condição de colisão iminente do moitão. O Sistema de definição da área de trabalho padrão permite que o operador selecione e defina previamente as áreas de trabalho seguras. Se o guindaste se aproxima dos limites predefinidos, advertências audiovisuais ajudam o operador a evitar obstruções no local de trabalho.

Cabine

Visão total, fabricada em aço com isolamento acústico e vidros de segurança ao redor. Assento de luxo incorpora apoio de braços hidráulicos montados de um único eixo controladores. Direção telescópica/ com inclinação com vários controles incorporados à coluna de direção. Outras características padrão incluem: aquecedor de água quente, ventilador de circulação de ar, janelas deslizantes laterais e traseira, clarabóia deslizante com limpador elétrico e protetor solar, lavagem/ limpeza elétrica de pára-brisa, extintor de incêndio, cinto de segurança, ar condicionado e luz dupla de trabalho.

Giro

Acionamento de giro planetário de uma velocidade, com freio úmido multidisco aplicado por pedal. Freio de giro aplicado por mola e liberado hidráulicamente. Trava mecânica da estrutura de giro de posição única, operada da cabine.
Velocidade máxima: 2,0 rpm.

Contrapeso

4,3 t fixado à superestrutura.

Sistema hidráulico

Duas bombas principais (1 de pistão e 1 de engrenagem) com capacidade combinada de 316,5 l/min.

Pressão máxima de operação: 275,7 bar.

Banco de válvulas de três seções com compensação de pressão. Filtro tipo linha de retorno com proteção de contorno de vazão total e indicador de manutenção. Cartucho substituível com taxa de filtração de 5/12/16 microns.

Reservatório hidráulico de 396 l. Entradas de teste de pressão do sistema.

Guincho

Redução planetária com freio úmido multidisco aplicado automaticamente por mola. Indicadores eletrônicos de rotação do tambor do guincho e seguidores do cabo do tambor do guincho.

Tração máxima de cabo único:

- 1ª camada: 5280 kg.
- 3ª camada: 4323 kg.
- 5ª camada: 3656 kg.

Tração máxima permitida do cabo:
5280 kg. com cabo classe 34x37.

Velocidade máxima de cabo único: 136 m/min.

Estrutura do cabo: 34w x K7, resistente à rotação.

Diâmetro do cabo: 16 mm.

Comprimento do cabo: Guincho principal: 137 m
Guincho auxiliar: 137 m.

Recollhimento máximo de cabo: 181 m.

Transportador



Estrutura do transportador

Estrutura da seção da caixa fabricada em aço de liga leve de alta resistência. Olhais combinados de elevação/fixação/reboque.



Estabilizadores

Quatro estabilizadores hidráulicos telescópicos de estágio único e vigas de caixa dupla com macacos invertidos e válvulas de retenção integradas.

Ajuste de três posições, 0%, 50% e totalmente estendidos.

Flutuadores dos estabilizadores do tipo liberação rápida, fabricados totalmente em aço, com 362 mm de diâmetro.

Carga máxima na patola do estabilizador: 26 300 kg.

Controles e indicador de nível do guindaste localizados na cabine.



Motor

Cummins QSB 6,7 l a diesel, seis cilindros, 119 kW (160 bhp) (Bruto) a 2500 rpm.

Torque máximo: 732 Nm (540 lb-ft) a 1500 rpm.



Transmissão

6 velocidades com mudança de faixa (3 velocidades x 2 faixas, em avanço ou marcha a ré).

Desconexão do eixo dianteiro para deslocamento 4 x 2.



Tração/direção

4 x 4

Direção hidráulica totalmente independente:

Dianteira: totalmente hidráulica controlada pelo volante de direção.

Traseira: totalmente hidráulica controlada por interruptor.

Oferece variações infinitas dos 4 modos de direção principais: somente dianteira, somente traseira, caranguejo e coordenada.

Indicador de direção traseira. Raio de curva: 7,62 m.



Eixos

Dianteira: tração/direção com diferencial e cubos de redução planetária de montagem rígida na estrutura.

Traseira: tração/direção com diferencial e cubos de redução planetária de montagem articulada na estrutura.



Pneus

Padrão 20.5 x 25 - 24 lonas oblíquas.

Opção: 16.0 x 25 - 28 lonas oblíquas.



Luzes

Iluminação completa incluindo indicadores direcionais, faróis, lanternas traseiras luzes de freio e de atenção de perigo.



Velocidade máxima

40 km/h a 2500 rpm.



Freios

Circuito totalmente hidráulico dividido operando em todas as rodas. Freio de estacionamento aplicado por mola e liberado hidráulicamente montado no eixo dianteiro.



Sistema elétrico

Quatro (4) baterias de 12 V livres de manutenção. Partida e iluminação de 24 V. Desconexão da bateria. Sistema de diagnóstico completo por barramento CAN.

*Equipamento opcional

- Pacote de guincho auxiliar: Inclui guincho auxiliar modelo HP15C-17G com indicador eletrônico de rotação do tambor, seguidor do cabo do tambor do guincho, 137 m de cabo classe 16 mm 35 x 7 e extremidade da lança com polia auxiliar.
- Pacote de luzes auxiliares e itens de conveniência: Inclui luz intermitente âmbar montada na cabine, luz de trabalho montada no guincho, holofotes de base dupla montados na lança, barra de luzes do IMC (na cabine) e tapete de borracha para o compartimento de armazenamento.
- Trava de giro mecânica tipo NYC de 360°
- Gancho de engate traseiro
- Bloqueios transversais do diferencial controlados na cabine (dianteiro e traseiro)
- Kit de download do registrador de eventos PAT
- Moitão de gancho de 4 polias



Axle • Eje • Eixo	1	2	Total weight • Peso total • Peso total
	t	t	
	13,0	14,3	27,3



Lifting Capacity • Capacidad de elevación • Capacidade de elevação	Sheaves • Poleas • Polias	Parts of line • Secciones de cable • Pernas de cabo	Total weight • Peso total • Peso total
27 t	5	2-6	262 kg
14 t	2	2-4	192 kg
7 t	H/B (swivel)	1	167 kg

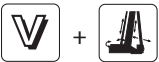

	Infinitely variable • Infinitamente variable • Infinidamente variável		Rope • Cable • Cabo	Permissible line pull max. • Tracción de cable máx. admisible • Tração máx. permissível do cabo	Nominal cable length • Largo nominal de cable • Comprimento nominal do cabo
	0 - 136 m/min	single line • cable sencillo • cabo único	16 mm / 137 m (6x37 class)	5280 kg	137 m
	0 - 136 m/min	single line • cable sencillo • cabo único	16 mm / 137 m (35x37 class)	5280 kg	137 m
	0 - 2 min ⁻¹				
	20° to 70°	approx. 20 s • aprox. 20 s • aprox. 20 s			
	8,8 to 29,0 m	approx. 44 s • aprox. 44 s • aprox. 44 s			

Dimensions • Dimensiones • Dimensões

	Tire size Tamaño de neumático Dimensões dos pneus	A	B	C	D	E	F	G	H	J	K	L
2 wheel steer Dirección en 2 ruedas Direção nas 2 rodas	20.5 x 25	13 563 mm	13 328 mm	10 899 mm	10 236 mm	10 007 mm	8138 mm	7021 mm	2055 mm	25°	23°	2606 mm
	16.0 x 25	13 563 mm	13 328 mm	10 899 mm	10 185 mm	9981 mm	8138 mm	7021 mm	2093 mm	26°	24°	2536 mm
4 wheel steer Dirección en 4 ruedas Direção nas 4 rodas	20.5 x 25	9797 mm	9490 mm	6732 mm	6061 mm	5832 mm	4000 mm	3498 mm	2055 mm	25°	23°	2606 mm
	16.0 x 25	9797 mm	9490 mm	6732 mm	6010 mm	5806 mm	4000 mm	3498 mm	2093 mm	26°	24°	2536 mm

Notes:

- All dimensions are for reference only • Todas las dimensiones son para referencia únicamente • Todas as dimensões são somente para referência
- Boom elevation is -3° to +76° • La elevación de la pluma de -3° a +76° • Elevação da lança é -3° à +76°
- Dimensions shown are based on 20.5 x 25 tires. • Las dimensiones mostradas están basadas sobre ruedas 20.5 x 25 • Dimensões mostradas são baseadas com pneus 20.5 x 25
- Add 35,4 mm for 16.0 x 25 tires • Agregue 35,4 mm para ruedas 16.0 x 25 • Adicione 35,4 mm para pneus 16.0 x 25

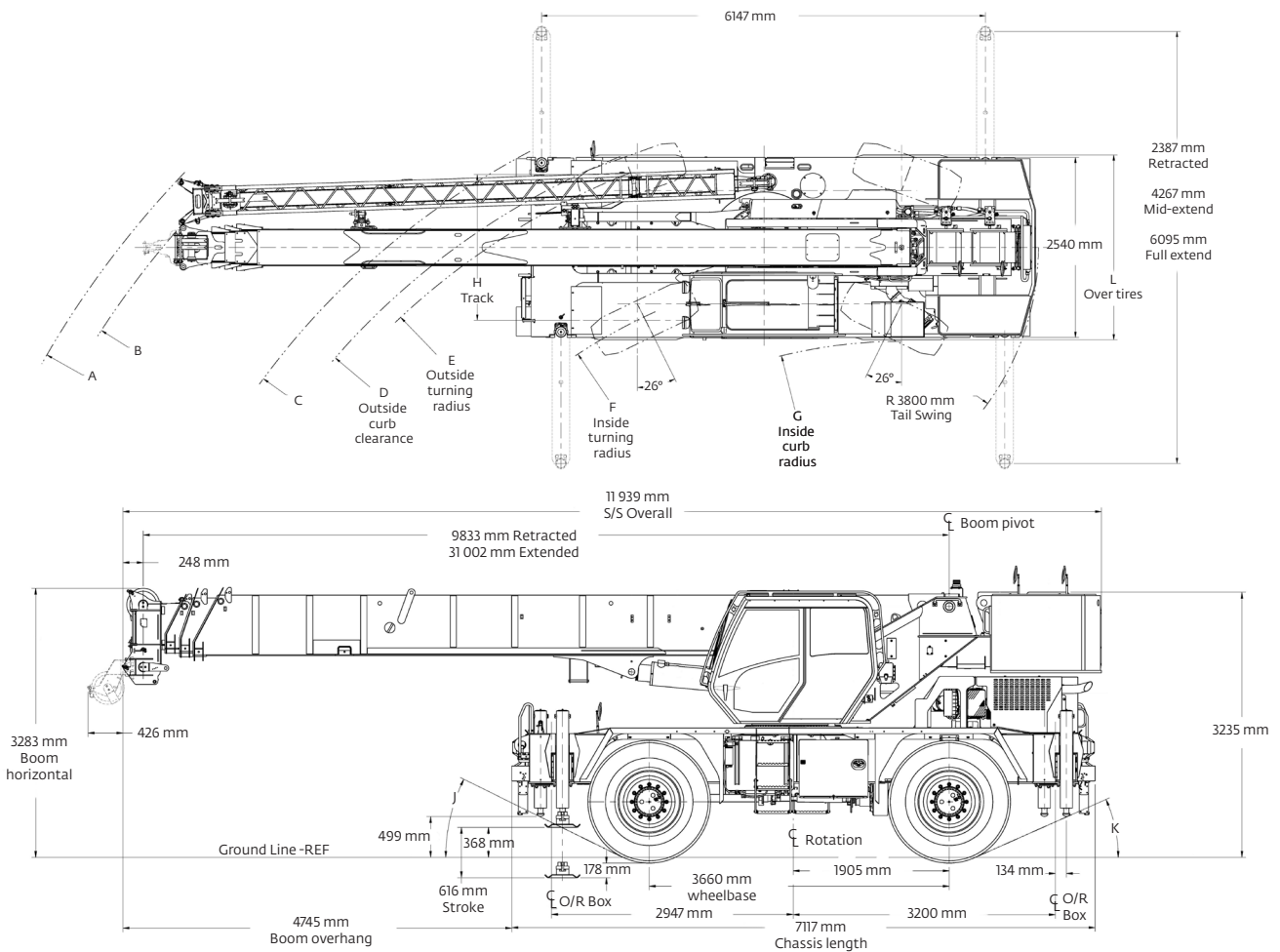

English	Español	Português do Brasil
S/S Overall	Total de superestructura	Superestrutura Geral
Retracted	Retraída	Retraído
Extended	Extendida	Extendido
Boom pivot	Punto de articulación	Pivô da lança
Outrigger (OR) Box	Caja de Estabilizadores	Caixa da Patola
Chassis length	Longitud de chasis	Comprimento do Chassis
Rotation	Rotación	Rotação
Wheelbase	Base de Ejes	Distância entre eixos
Stroke	Extensión	Atuação do cilindro
Ground line reference (REF)	Línea de Referencia con el suelo	Linha de referênciã do solo
Boom overhang	Sobre vuelo de la pluma	Beiral da Lança

English	Español	Português do Brasil
Boom horizontal	Con pluma horizontal	Lança horizontal
Mid-Extend	Extensión intermedia	Meio extendido
Full extend	Extensión total	Totalmente extendido
Over tires	Sobre ruedas	Sobre Pneus
Tailswing	Giro de cola	Giro traseiro
Inside curb clearance	Radio interno de giro	Folga interna de freio
Inside turning radius	Línea de radio de giro interna	Raio interno de giro
Track	Pista de avance	Distância entre eixos
Outside turning radius	Línea de radio de giro externa	Raio externo de giro
Outside curb clearance	Radio externo de giro	Folga externa do freio

Weights • Peso • Peso

	Gross	Front	Rear
<p>Basic machine including 31,0 m main boom, main hoist with 137,0 m of rope, full counter weight + IPO, 6,8 t headache ball, and 35 t hookblock.</p> <p>Máquina básica incluyendo 102 ft (31.0 m) de pluma principal, malacate principal con 450 ft (137.0 m) de cable, contrapeso completo "IPO", gancho bola para 7.5 tons (6.8 Mton) y gancho bloque de 40 tons (35 Mton).</p> <p>Maquina Básica incluindo lança principal de 31,0 m, guincho principal com 137,0 m de cabo, contrapesos completos + bola de 6,8 t, e moitão para 35 t</p>	27 693 kg	13 239 kg	14 454 kg
<p>Add: Auxiliary hoist + 137,0 t of 35 x 7 hoist cable and auxiliary boom nose ILO IPO counter weight</p> <p>Agregue: Malacate Auxiliar + 450 ft (137 m) de cable 35 x 7 y polea auxiliar en cabezal + Contrapeso ILO IPO.</p> <p>Adicione: Guincho Auxiliar + 137,0 m de cabos de 35 x 7 e ponta de lança auxiliar Contrapeso ILO IPO</p>	27 915 kg	13 320 kg	14 595 kg
<p>Add: 7,9 m - 13,7 m telescopic boom extension + extension hangers</p> <p>Agregue: Extensión de pluma telescópica de 26 ft – 45 ft (7.9 m – 13.7 m) + soportes de extensión.</p> <p>Adicione: Extensão de Lança Telescópica de 7,9 m - 13,7 m</p>	28 775 kg	14 747 kg	14 028 kg

Working range • Alcance de trabajo • Faixa de trabalho

Working range • Alcance de trabajo • Faixa de trabalho



9,8 – 31,0 m



100%



360°



4,3 t

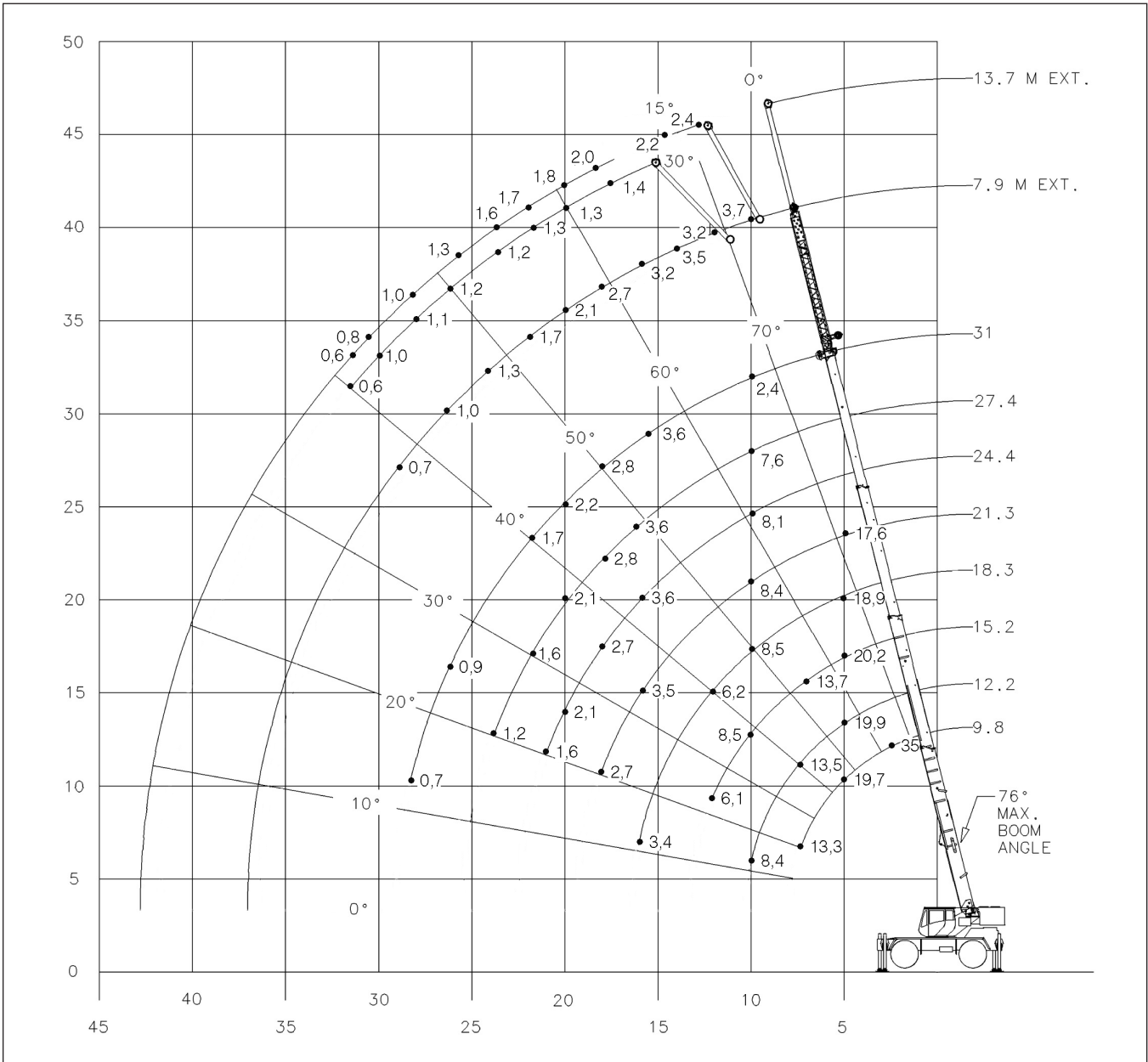

	H (mm) (t)
	2,5 m

Notes • Notas • Notas

Lifting capacities according to DIN/ISO • 85%

Warning: THIS CHART IS ONLY A GUIDE. The Notes below are for illustration only and should not be relied upon to operate the crane.

The individual crane's load chart, operating instructions and other instruction plates must be read and understood prior to operating the crane.

DIN/ISO: The mechanical strength complies with DIN 15018, part 3. Tipping conditions are governed by DIN 15019, part 2 and ISO 4305 standards. They also take into account the requirements of prEN 13000: 2003 and therefore comply with the requirements of the EU machinery directive.

85%: Capacities are in accordance with SAE J1063 and do not exceed 85% of the tipping load (SAE J1289 for outriggers 50% and 0% extended) as determined by SAE J765.

1. Capacities given do not include the weight of hookblocks, slings, auxiliary lifting equipment and load handling devices. Their weights MUST be added to the load to be lifted. When more than minimum required reeving is used, the additional rope weight shall be considered part of the load.
2. All capacities are for crane on firm, level surface. It may be necessary to have structural supports under the outrigger floats or tyres to spread the load to a larger bearing surface.
3. When either boom length or radius or both are between values listed, the smallest load shown at either the next larger radius or boom length shall be used.
4. For outrigger operation, ALL outriggers shall be fully extended with tyres raised free of ground before raising the boom or lifting loads.
5. Tyres shall be inflated to the recommended pressure before lifting on rubber.

Capacidades de elevación de acuerdo a las normas DIN/ISO • 85%

Advertencia: ESTE GRÁFICO ES SOLAMENTE UNA GUÍA. Las notas a continuación son para ilustración solamente y no se deberán utilizar como guía para manejar la grúa.

La tabla de carga, instrucciones de funcionamiento y otras chapas de instrucciones de la grúa individual se deben leer y entender antes de manejar la grúa.

DIN/ISO: La resistencia mecánica es de conformidad con la parte 3 de la norma DIN 15018. Las condiciones de vuelco son regidas por las normas DIN 15019, parte 2, e ISO 4305. También toman en cuenta los requisitos establecidos por la norma prEN 13000: 2003 y así cumplen con los requisitos de la directiva de maquinarias de la UE.

85%: Las capacidades son de acuerdo con la norma SAE J1063 y no exceden de 85% de la carga de vuelco (SAE J1289 para estabilizadores 50% y 0% extendidos) según lo determinado por la norma SAE J765.

1. Las capacidades dadas no incluyen el peso de los aparejos de gancho, eslingas, equipo de elevación auxiliar y los dispositivos de manejo de cargas. Sus pesos DEBEN añadirse al de la carga a ser elevada. Cuando se utilice más del enhebrado mínimo requerido, el peso adicional del cable deber ser considerado como parte de la carga.
2. Todas las capacidades son para una grúa situada sobre una superficie firme y nivelada. Puede ser necesario colocar bajo los neumáticos o las bases de los estabilizadores apoyos estructurales para distribuir la carga sobre una superficie de apoyo más grande.
3. Cuando el largo o el radio de la pluma, o ambos, estén entre los valores indicados en las tablas, se deberá usar la carga menor indicada en el próximo radio o largo de pluma mayor.
4. Para trabajos sobre estabilizadores, TODOS los estabilizadores deben estar completamente extendidos con los neumáticos elevados del suelo antes de elevar la pluma o levantar cargas.
5. Los neumáticos deberán estar inflados a la presión recomendada antes de elevar cargas sobre neumáticos.

Capacidades de elevação de acordo com normas DIN/ISO • 85%

Atenção: ESTA TABELA É APENAS UM GUIA. As notas abaixo são apenas para ilustração e não se deve tomá-las como base para operar o guindaste. A tabela de carga individual do guindaste, as instruções de operação e outras placas de instruções devem ser lidas e entendidas antes da operação do guindaste.

DIN/ISO: a resistência mecânica está em conformidade com a norma DIN 15018, parte 3. As condições de tombamento são regidas pelas normas DIN 15019, parte 2 e ISO 4305. Elas também levam em conta as exigências da prEN 13000: 2003 e, portanto, estão em conformidade com as exigências da diretiva para maquinário da UE.

85%: as capacidades estão de acordo com a norma SAE J1063 e não excedem 85% da carga de tombamento (SAE J1289 para estabilizadores 50% e 0% estendidos) como determinado pela norma SAE J765.

1. As capacidades fornecidas não incluem o peso dos moitões de gancho, lingas, equipamento auxiliar de elevação e dispositivos de movimentação de carga. Seus pesos DEVEM ser somados ao da carga a ser elevada. Quando é usada mais que a passagem de cabo mínima necessária, o peso do cabo adicional deve ser considerado parte da carga.
2. Todas as capacidades consideram o guindaste sobre superfície firme e nivelada. Pode ser necessário ter suportes estruturais sob os flutuadores dos estabilizadores ou pneus para distribuir a carga para uma superfície de sustentação maior.
3. Quando o comprimento da lança ou o raio ou ambos estiverem entre os valores listados, deve ser usada a menor carga mostrada no próximo maior raio ou comprimento da lança.
4. Para operação dos estabilizadores, TODOS os estabilizadores devem estar totalmente estendidos com os pneus elevados acima do solo antes da elevação da lança ou de cargas.
5. Os pneus devem estar calibrados de acordo com a pressão recomendada antes de realizar a elevação sobre pneus.

Load charts • Tablas de carga • Tabelas de carga

Telescopic boom • Pluma telescópica • Lança telescópica

 9,8 – 31,0 m
  100%
  360°
  4,3 t



DIN/ISO

m	9,8	12,2	15,2	18,3	21,3	24,4	27,4	31,0	m
2,5	35,000								2,5
3,0	32,725	22,975	21,975						3,0
3,5	29,000	22,975	21,975						3,5
4,0	25,150	22,975	21,975	21,025					4,0
4,5	22,125	22,350	21,975	20,150					4,5
5,0	19,675	19,900	20,075	18,925	17,550				5,0
6,0	15,950	16,175	16,350	16,250	14,275	13,450			6,0
7,0	13,250	13,475	13,675	13,775	12,650	12,075	9,975		7,0
8,0		11,450	11,625	11,725	11,250	10,725	9,530	8,375	8,0
9,0		9,835	9,900	9,885	9,780	9,405	8,470	7,980	9,0
10,0		8,420	8,545	8,545	8,360	8,060	7,625	7,350	10,0
12,0			6,070	6,130	6,200	6,110	5,930	5,720	12,0
14,0				4,525	4,620	4,670	4,635	4,475	14,0
16,0				3,415	3,500	3,560	3,570	3,560	16,0
18,0					2,675	2,730	2,760	2,775	18,0
20,0						2,090	2,130	2,160	20,0
22,0						1,585	1,630	1,670	22,0
24,0							1,220	1,265	24,0
26,0								0,935	26,0
28,0								0,650	28,0

Ag-829-104284



85%

m	9,8	12,2	15,2	18,3	21,3	24,4	27,4	31,0	m
2,5	35,000								2,5
3,0	32,725	22,975	21,975						3,0
3,5	29,000	22,975	21,975						3,5
4,0	25,150	22,975	21,975	21,025					4,0
4,5	22,125	22,350	21,975	20,150					4,5
5,0	19,675	19,900	20,075	18,925	17,550				5,0
6,0	15,950	16,175	16,350	16,250	14,275	13,450			6,0
7,0	13,250	13,475	13,675	13,775	12,650	12,075	9,975		7,0
8,0		11,450	11,625	11,725	11,250	10,725	9,530	8,375	8,0
9,0		9,850	10,025	10,125	10,025	9,585	8,470	7,980	9,0
10,0		8,560	8,750	8,845	8,920	8,625	7,625	7,350	10,0
12,0			6,710	6,740	6,815	6,895	6,245	6,100	12,0
14,0				5,060	5,135	5,190	5,190	5,140	14,0
16,0				3,880	3,965	4,010	4,020	4,025	16,0
18,0					3,085	3,145	3,160	3,175	18,0
20,0						2,465	2,505	2,525	20,0
22,0						1,930	1,970	2,010	22,0
24,0							1,540	1,585	24,0
26,0								1,230	26,0
28,0								0,935	28,0

Ag-829-104283

Load charts • Tablas de carga • Tabelas de carga

Telescopic boom • Pluma telescópica • Lança telescópica





 9,8 – 31,0 m
  50%
  360°
  4,3 t





DIN/ISO - 85%

m	9,8	12,2	15,2	18,3	21,3	24,4	27,4	31,0	m
2,5	34,375								2,5
3,0	30,400	22,975	21,975						3,0
3,5	27,175	22,975	21,975						3,5
4,0	23,850	22,175	20,400	18,875					4,0
4,5	19,725	18,575	17,250	16,100					4,5
5,0	16,700	15,875	14,875	13,950	13,150				5,0
6,0	12,575	12,075	11,475	10,875	10,325	9,845			6,0
7,0	9,410	9,555	9,200	8,770	8,380	8,015	7,690		7,0
8,0		7,530	7,515	7,230	6,935	6,655	6,405	6,115	8,0
9,0		6,010	6,160	6,045	5,830	5,605	5,405	5,175	9,0
10,0		4,880	5,030	5,085	4,955	4,770	4,610	4,420	10,0
12,0			3,460	3,515	3,620	3,520	3,410	3,275	12,0
14,0				2,475	2,570	2,610	2,550	2,450	14,0
16,0				1,735	1,810	1,875	1,890	1,825	16,0
18,0					1,245	1,300	1,335	1,325	18,0
20,0						0,855	0,890	0,925	20,0
22,0							0,535	0,580	22,0

AG-829-104285

 9,8 – 31,0 m
  0%
  360°
  4,3 t



DIN/ISO - 85%

m	9,8	12,2	15,2	18,3	21,3	24,4	27,4	31,0	m
2,5	19,750								2,5
3,0	15,500	14,550	13,375						3,0
3,5	12,600	11,975	11,150						3,5
4,0	10,450	10,025	9,470	8,860					4,0
4,5	8,850	8,540	8,150	7,665					4,5
5,0	7,575	7,350	7,060	6,695	6,340				5,0
6,0	5,700	5,580	5,415	5,200	4,965	4,715			6,0
7,0	4,315	4,330	4,235	4,090	3,945	3,770	3,605		7,0
8,0		3,400	3,345	3,250	3,150	3,030	2,910	2,750	8,0
9,0		2,635	2,660	2,590	2,520	2,430	2,350	2,225	9,0
10,0		2,000	2,105	2,060	2,005	1,940	1,880	1,790	10,0
12,0			1,240	1,260	1,230	1,190	1,155	1,100	12,0
14,0				0,675	0,675	0,645	0,630	0,590	14,0

AG-829-104286

Load charts • Tablas de carga • Tabelas de carga

Telescopic boom • Pluma telescópica • Lança telescópica



7,9 - 13,7 m



20.5x25 / 0 km/h



360°



4,3 t



DIN/ISO

Radius m	9,8	12,2	15,2	18,3	Radius m
3,0	10,900	10,925	10,450		3,0
3,5	10,075	9,755	9,080		3,5
4,0	8,480	8,210	7,740		4,0
4,5	6,880	7,000	6,650	6,250	4,5
5,0	5,685	5,825	5,760	5,455	5,0
6,0	4,015	4,145	4,380	4,200	6,0
7,0	2,900	3,030	3,220	3,270	7,0
8,0		2,230	2,395	2,450	8,0
9,0		1,635	1,775	1,835	9,0
10,0		1,170	1,290	1,355	10,0
12,0			0,590	0,660	12,0

AG-829-104289



85%

Radius m	9,8	12,2	15,2	18,3	Radius m
3,0	10,900	10,925	10,450		3,0
3,5	10,075	10,225	9,975		3,5
4,0	8,930	9,145	9,095		4,0
4,5	7,655	7,945	8,085	6,315	4,5
5,0	6,705	6,850	7,130	6,055	5,0
6,0	4,815	4,955	5,205	5,200	6,0
7,0	3,560	3,690	3,895	3,945	7,0
8,0		2,790	2,960	3,020	8,0
9,0		2,115	2,260	2,325	9,0
10,0		1,590	1,720	1,785	10,0
12,0			0,925	1,000	12,0

AG-829-104287

Load charts • Tablas de carga • Tabelas de carga

Telescopic boom • Pluma telescópica • Lança telescópica



9,8 – 18,3 m



4 km/h



0°



4,3 t



DIN/ISO

Radius m	9,8	12,2	15,2	18,3	Radius m
3,0	12,300	12,200			3,0
3,5	11,025	10,975			3,5
4,0	9,835	9,855			4,0
4,5	8,740	8,805	8,820		4,5
5,0	7,865	7,925	8,065		5,0
6,0	6,365	6,590	6,720	6,610	6,0
7,0	5,250	5,525	5,675	5,710	7,0
8,0		4,610	4,770	4,815	8,0
9,0		3,870	4,020	4,095	9,0
10,0		3,265	3,425	3,505	10,0
12,0			2,315	2,395	12,0
14,0				1,630	14,0
16,0				1,075	16,0

AG-829-104290







85%





Radius m	9,8	12,2	15,2	18,3	Radius m
3,0	12,300	12,200			3,0
3,5	11,025	10,975			3,5
4,0	9,835	9,855			4,0
4,5	8,740	8,805	8,820		4,5
5,0	7,865	7,925	8,065		5,0
6,0	6,365	6,590	6,720	6,610	6,0
7,0	5,250	5,525	5,675	5,710	7,0
8,0		4,610	4,770	4,815	8,0
9,0		3,870	4,020	4,095	9,0
10,0		3,265	3,425	3,505	10,0
12,0			2,450	2,530	12,0
14,0				1,815	14,0
16,0				1,255	16,0

AG-829-104288

Load charts • Tablas de carga • Tabelas de carga

Swingaway • Plumín articulado • Oscilante





 31 m
  7,9 m
  100%
  360°
  4,3 t





 DIN / ISO
 
 85%

Radius m	7,9 m		7,9 m		Radius m
	0°	30°	0°	30°	
10,0	3,715		3,715		10,0
12,0	3,175		3,715		12,0
14,0	3,500	2,620	3,715	2,620	14,0
16,0	3,200	2,545	3,550	2,545	16,0
18,0	2,630	2,270	3,010	2,270	18,0
20,0	2,100	1,995	2,430	1,995	20,0
22,0	1,665	1,760	1,955	1,760	22,0
24,0	1,280	1,535	1,555	1,555	24,0
26,0	0,955	1,165	1,215	1,390	26,0
28,0	0,685	0,855	0,930	1,085	28,0
30,0		0,590	0,680	0,800	30,0
32,0				0,545	32,0

AG-829-104332

AG-829-104331

 31 m
  7,9 - 13,7 m
  100%
  360°
  4,3 t



 DIN/ISO

Radius m	7,9 m		13,7 m		Radius m
	0°	30°	0°	30°	
12,0	3,800		2,380		12,0
14,0	3,500		2,360		14,0
16,0	3,200	2,735	2,200	1,630	16,0
18,0	2,630	2,565	1,975	1,565	18,0
20,0	2,100	2,420	1,800	1,360	20,0
22,0	1,665	2,150	1,690	1,305	22,0
24,0	1,280	1,845	1,440	1,250	24,0
26,0	1,075	1,410	1,375	1,200	26,0
28,0	0,955	1,165	1,285	1,155	28,0
30,0	0,785	1,010	1,195	1,115	30,0
32,0	0,535	0,855	1,070	1,070	32,0
34,0		0,590	0,775	0,935	34,0
			0,575	0,710	32,0
				0,515	34,0

AG-829-104325

 85%

Radius m	7,9 m		13,7 m		Radius m
	0°	30°	0°	30°	
12,0	4,335		2,380		12,0
14,0	3,925		2,360		14,0
16,0	3,550	2,735	2,200	1,630	16,0
18,0	3,105	2,565	1,975	1,565	18,0
20,0	2,685	2,420	1,800	1,360	20,0
22,0	2,190	2,150	1,690	1,305	22,0
24,0	1,735	1,845	1,440	1,250	24,0
26,0	1,355	1,410	1,375	1,200	26,0
28,0	1,040	1,165	1,285	1,155	28,0
30,0	0,770	1,010	1,195	1,115	30,0
32,0	0,540	0,855	1,070	1,070	32,0
34,0		0,590	0,775	0,935	34,0
36,0			0,510	0,605	36,0

AG-829-104324

Load charts • Tablas de carga • Tabelas de carga

Swingaway • Plumín articulado • Oscilante



31 m



7,9 m



50%



360°



4,3 t



DIN / ISO - 85%

Radius m	7,9 m		Radius m
	0°	30°	
10,0	3,715		10,0
12,0	2,955		12,0
14,0	2,190	2,620	14,0
16,0	1,610	2,070	16,0
18,0	1,155	1,545	18,0
20,0	0,785	1,120	20,0
22,0		0,765	22,0

AG-825-0104396



31 m



7,9 - 13,7 m



50%



360°



4,3 t



DIN / ISO - 85%

Radius m	7,9 m			13,7 m			Radius m
	0°	15°	30°	0°	15°	30°	
12,0	2,955	3,295		2,380			12,0
14,0	2,190	2,475	2,735	2,360			14,0
16,0	1,610	1,850	2,070	1,890	1,630		16,0
18,0	1,155	1,360	1,545	1,445	1,565	1,360	18,0
20,0	0,785	0,965	1,120	1,085	1,380	1,305	20,0
22,0		0,635	0,765	0,785	1,045	1,250	22,0
24,0				0,535	0,765	0,970	24,0
26,0					0,525	0,705	26,0

AG-825-104336

Symbols glossary • Glosario de símbolos • Glossário de símbolos

Symbols • Símbolos • Símbolos



Axles
Ejes
Eixos



Crane functions
Funciones de la grúa
Funções do Guindaste



Hookblock / Capacity
Aparejo de gancho/capacidad
Moitões de gancho/Capacidade



Speed
Velocidad
Velocidade



Axle load
Carga del eje
Capacidade do eixo



Crane travel
Propulsión de la grúa
Guindaste rodoviário



Hydraulic system
Sistema hidráulico
Sistema hidráulico



Suspension
Suspensión
Suspensão



Boom
Pluma
Lança



Drive/Steer
Tracción/dirección
Tração/direção



Lattice extension
Extensión de celosía
Extensão Treliçada



Transmission / Gear
Transmisión/marcha
Transmissão/Engrenagem



Boom elevation
Elevación de pluma
Elevação da lança



Electrical system
Sistema eléctrico
Sistema elétrico



Lattice extension (luffing)
Extensión de celosía (abatible)
Extensão treliçada (inclinável)



Travel speed
Velocidad de propulsión
Velocidade de viagem



Boom telescoping
Telescopización de la pluma
Lança telescópica



Engine
Motor
Motor



Luffing Jib
Plumín abatible
Jib com inclinação



Tyres
Neumáticos
Pneus



Brakes
Frenos
Freios



Free on wheels
Libre sobre ruedas
Livre sobre rodas



Low range
Marcha lenta
Marcha reduzida



Cab
Cabina
Cabine



Gradeability
Capacidad de pendiente
Capacidade de subida de rampa



Outriggers
Estabilizadores
Estabilizadores



Carrier frame
Bastidor de vehículo
Estrutura do transportador



Main hoist
Malacate principal
Guincho principal



Radius
Radio
Raio



Counterweight
Contrapeso
Contrapeso



Auxiliary hoist
Malacate auxiliar
Guincho auxiliar



Slewing/Working range
Gama de inclinación/trabajo
Faixa de giro/trabalho

Manitowoc Cranes

Regional headquarters

Americas

Manitowoc, Wisconsin, USA

Tel: +1 920 684 6621

Fax: +1 920 683 6277

Shady Grove, Pennsylvania, USA

Tel: +1 717 597 8121

Fax: +1 717 597 4062

Europe, Middle East, Africa

Ecully, France

Tel: +33 (0)4 72 18 20 20

Fax: +33 (0)4 72 18 20 00

China

Shanghai, China

Tel: +86 21 6457 0066

Fax: +86 21 6457 4955

Greater Asia-Pacific

Singapore

Tel: +65 6264 1188

Fax: +65 6862 4040

Regional offices

Chile

Santiago

Manitowoc Cranes

America del Sur

Rosario Norte 615

Oficina 1801

Las Condes Santiago

Chile

Telefono 56 2 923 8500

Mexico

Monterrey

Manitowoc Crane Group Mexico

Ave. Lazaro Cardenas #1810 Piso 11

Oficina 1108

Torre Capitel Colonia

Paseo Residencial

CP. 64920, Monterrey, N.L.

Mexico

Telefono 52 8 113 53 0300

Brazil

Barueri

Rua São Paulo, 157

Alphaville Industrial,

Barueri SP

06465-130

Brazil

Telefone +55 11 3103 0228

This document is non-contractual. Constant improvement and engineering progress make it necessary that we reserve the right to make specification, equipment, and price changes without notice. Illustrations shown may include optional equipment and accessories and may not include all standard equipment.

Este documento no es contractual. El perfeccionamiento constante y el avance tecnológico hacen necesario que la empresa se reserve el derecho de efectuar cambios en las especificaciones, equipo y precios sin previo aviso. En las ilustraciones se puede incluir equipo y accesorios opcionales y es posible que no se muestre el equipo normal.

Este documento não se reveste de qualquer carácter contratual. A introdução constante de melhorias e o progresso da engenharia tornam necessário reservarmos o direito de introduzir alterações nas características técnicas, no equipamento e no preço sem qualquer aviso prévio. As ilustrações aqui apresentadas podem incluir equipamento e acessórios adicionais, podendo não incluir todo o equipamento padrão.



SISTERMI

Movimentação e Içamento de Cargas

**Você pode entrar em contato conosco
através dos telefones**

 **[27] 3398-1233**

 **[27] 99690-0505**

 **[27] 99817-8420**

e no e-mail

 **comercial@sistermi.com.br**